

# Tech - Aero Designs

## “FlexReg” PLR5-I Quickstart Guide

Thank you for purchasing the Tech-Aero Designs FlexReg PLR5-I. The FlexReg has an up/down programmable output that stores any of 32 points over an adjustment range from 5.75 to 6.65 volts +/- 1% accuracy, providing fine control of the regulated voltage to the receiver and servos. The factory setting of the PLR5 is 6.2V, which may be changed with the separately available E-Z Set programmer.

Simply plug the RX PWR connector into the battery power connection on your receiver and plug the battery into the Battery connector to the flight pack battery. Power to the receiver is controlled by the PLR5-I On/OFF switch; no other switch is necessary.

When using the DSC function of your radio, be sure to connect the RX PWR lead connects to the receiver power connector that also supports the DSC function. Not every radio supports DSC, so please check with the instructions provided by the manufacturer. The DSC cord from your radio transmitter plugs into the PLR5 DSC/Charger connection.

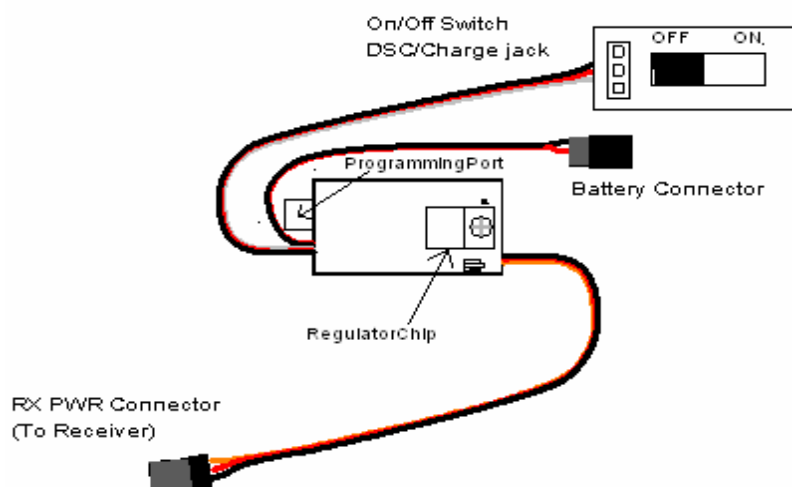

The DSC/Charger connection may also be used to perform pre-flight checks of the battery condition. You may use a typical hobby type expanded scale voltmeter (ESV) or you may use the Tech-Aero “E-Z Set” Programmer for doing pre-flight checks. For convenience, the DSC/Charger connection may also be used to connect a battery charger that is matched to the battery technology (NiCad or NiMH), battery voltage and capacity. The PLR5 must be switched off for battery charging. It is vital that you follow all of the safety precautions and battery charging instructions for both the battery and the battery charger that you are using. Do not charge LiIon or LiPo batteries with the PLR5 attached.

Mount the PLR5 with the topside exposed to air in the model cabin (regulator chip visible). Use a piece of 1/4” or thicker foam padding placed underneath and fasten with a Velcro strip around the mid-section. Do not over tighten the Velcro strip! Make it just snug enough to press the unit lightly into the foam padding beneath and also be sure that the strap does not cover up the body of the regulator chip.

A single FlexReg PLR5 may be used in typical model airplanes up to about 84” wingspan, weighing less than 15 lbs and utilizing 6 or fewer digital servos. For models of this size with unusually large control surfaces (3D capable) or for models up to about 105” and 25 lbs weight, a 2<sup>nd</sup> PLR5 is required to handle the additional load. A 2<sup>nd</sup> PLR5 is also required if more than 6 high torque (more than 120 oz-in) servos are used. For more advanced user requirements, a full technical manual is available at the Tech\_Aero website at <http://www.tech-aero.net>.